

# User information

## ***Fill level indicator for rain water storage tanks***

**Article – No.: 351013**

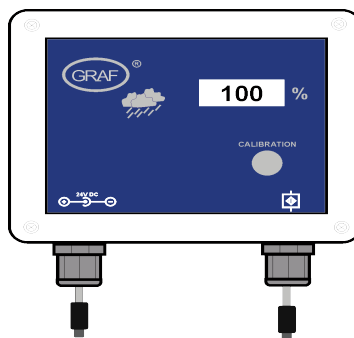

We congratulate you on the purchase of our fill level measuring device. You have purchased a high-quality product built to the highest standards of modern technology. Before you start to assemble or operate the equipment, please read the user information with care and check exactly the parts supply for completeness.

Included in the delivery are:

1. The fill level indicator.
2. The wall power supply.
3. The stainless steel measurement probe (red and white connection cables approx. 3m long).
4. The 20m long data cable.
5. The Measurement sensor.
6. Installation material.

**Otto Graf GmbH**  
**Kunststofferzeugnisse**

**Carl- Zeiss- Str. 2-6**  
**D 79 331 Teningen**

**Tel.: +49 7641 5890**  
**Fax: +49 7641 58950**

# 1. Safety Instructions

Please read carefully the safety and instruction manual before using this device! Follow all instructions that are in the User Guide (Manual) to achieve the optimal performance. Please keep these safety and operating instructions safe for further use.

## General Safety Instructions / Symbol Explanation



- refers to an information



- means warning and indicates a special situation



- indicates a hazardous situation which may cause to heavy or serious injury or even death

### 1.1 Personnel

The installation, commissioning and dismantling of the device must be done only by



trained and authorized personnel. During installation, it is necessary to pay attention to the safety regulations defined by the user and local laws and rules.

### 1.2 Proper Use of the Device

The equipment is designed exclusively for the intended purpose specified in the manual. Any other use and / or misuse of the device can lead to unpredictable risks including death and causes the loss of all the claims against the manufacturer.

### 1.3 Limitation of the Liability

The manufacturer would not take over any liability for damages resulting from:

- the usage of the device by untrained and unauthorized personnel,



- use of device for not intended purpose

- opening and/or manipulation of the device

- not following the manual and safety instructions

### 1.4 Electric Current

**!!Danger of life from electric current!!**

Direct contact to the parts of the device will cause an electric shock. In case of damage to the insulation, the device must be switched off immediately and the damaged area must be de-energized.



While maintaining on the device, ensure that the power supply is off at all times and make sure the device is de-energized.

### 1.5 Electrical Shock

If objects (e.g. hairpins, needles or coins) or liquids fall into the device, it can



cause life threatening electrical short-circuits, which can lead to fire. The user has to make sure that above mentioned objects, especially made of metal and/ or liquid things, will not fall in to the device intentionally or unintentionally.

### 1.6 Safety Operations



The operation and use of the device is to be done by instructed and authorized personnel only.

## 1.7 Power Supply

The equipment exclusively operates with the operating voltage indicated in the manual.

## 1.8 Cable Connection



When installing the cable connections, the user needs to pay attention to the safety regulations. Always pay attention to the connection to the protective earth ground! Pay attention when connecting with other devices, that those have to be of the same earth potential (same heavy current/voltage side).

## 1.9 Ventilation

The equipment must be installed in so that good ventilation to the device is ensured. Do not put any covering objects on the device, such as newspapers, books or towels.

## 1.10 Water and Moisture



The device is not allowed to operate in close vicinity of electrical conductive liquids or moist areas. It is not allowed to place any liquid things on the device or in the nearby area of the device.

**Attention: Danger of Electric Shocks!**

## 1.11 Temperature and Heat

The operating temperature of the device is defined in the specifications. The device must not be placed near things which produce heat such as to blowers, heaters, furnaces or other devices.

## 1.12 Opening the Device



**Disconnect the mains plug before opening the device!**

There is a risk of electrical shock when touching the parts inside the device. It is not permitted to make any changes in the device.

## 1.13 Cleaning



Do not use any volatile solvents such as alcohol, diluents, gasoline etc. to clean the device. Only use a dry, clean cloth.

## 1.14 Unusual Smell



If any unusual smoke or smell occurs, immediately switch off of the device and remove it from the main power supply! Contact your dealer or the manufacturer.

## 1.15 Fuses

**The replacement of the fuses in the device is only permitted by trained and authorized technical staff.**



The change of the fuses is only allowed when the device is switched off and is removed from the main power supply. Otherwise there is a risk of electric shocks.

The security functions and safety values are mentioned in the manual. The guarantee for this equipment will expire in case of using other fuses than those specified in the manual.

## 1.16 Repairing

The user is not allowed to perform the maintenance work by himself, except for those specified in the manual. All maintenance and repair work must be done by trained and authorized technical personnel.

## 1.17 Important notes of safety

**Please, read and follow safety instructions carefully before assembly or using the device!**

The assembly place must allow all possible safety precautions when laying the attached cables. Power supply cables and data cables may not be damaged or squeezed for any reasons. Plan the assembly place so that you can reach the wall power supply easily and unplug it from the electrical outlet in dangerous situations.

Choose the assembly place so that children cannot play or be near to the device and at its connections without supervision.

At chosen intervals in this hand book we will give directions for safety precautions. These safety precautions have been specially marked.

## 2. Description and intended use

The Fill level indicator has been developed especially for rain water usage. The device was designed for use in a **domestic** environment.

Synthetic material tanks are used. Cement and metal tanks are only conditionally usable. With the calibration function the system is coordinated to the different tank heights. The fill level in the tank is shown in 1% steps by a 3-digit LCD-display. The sensor electronics work with a 12 volt of low current and is reverse polarity protected; it is attached to the main device with a 20 m long data cable. As soon as the calibration and the assembly are completed no further setting up is necessary. The reference value for a 100% fill level remains stored in the case of a power failure.

## 3. Description of the equipment

Performance features:

- Fill level indicator in 1% steps
- Status LED which shows the operation in progress
- Self calibrating routine
- Permanent supervision of the sensor electronics
- Error messages in the error code

The following picture shows your newly acquired device:

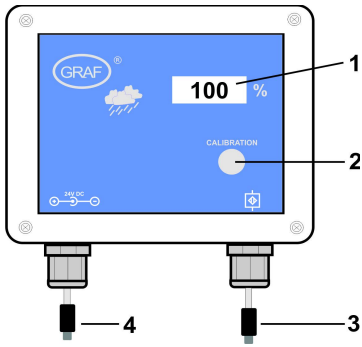

- 1: LCD- Display
- 2: Button for setting the maximum filling level coordination
- 3: Connector for the data cable
- 4: Connector for the wall power supply

Picture 1: Overall equipment list

**Technical data:**

**Fill level indicator**

Operating voltage : 24V DC  
 Power consumption : 0,9W  
 Output voltage : 12V DC

**Sensor electronics**

Measuring voltage : 12V DC  
 Measuring frequency : 200Hz - 20KHz  
 Cable length : max. 50m  
 Tank depth : 0,3m to 3m (*Sensor optionally available up to 6m*)

Measurements (LxWxD) : 120x79x59mm      Measurements (LxWxD) : 80x80x55mm  
 Protection level : IP54                      Protection level : IP54

**Wall power supply**

Operating voltage : 100V AC bis 240V AC  
 Frequency : 50Hz bis 60Hz  
 Output current : 1A  
 Protection level : II (protective insulation)

## 4. Assembly

### 4.1 Housing the control electronic

The assembly of the control electronic must be closed to the mains electrical supply socket. To fasten the top two mounting holes in the case are sufficient.

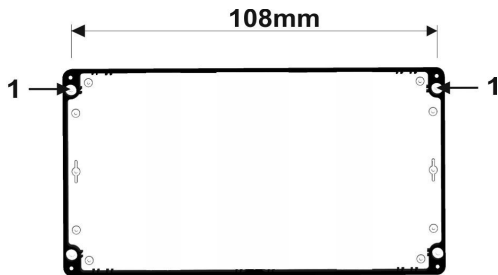

1: Mounting holes of the housing

Picture 2: Mounting holes

Mark out the hole positions at a distance of 108mm on the selected wall position and drill accordingly. Please use the enclosed mounting materials (dowel plugs and screws). Before mounting the unit you must first open the cover. To do this, loosen the 4 screws visible from the front, flip the cover upwards and hold securely in position. Insert the screws into the mounting holes of the housing (**Pos. 1** in picture 2) and screw the unit securely to the wall. Now reclose the cover and screw firmly into place.

### 4.2 Connection sensors and data cable

The sensor electronics comprise of a stainless steel probe [22] with a red and a white connecting cable [27] and the sensor measurement pick-up [28].

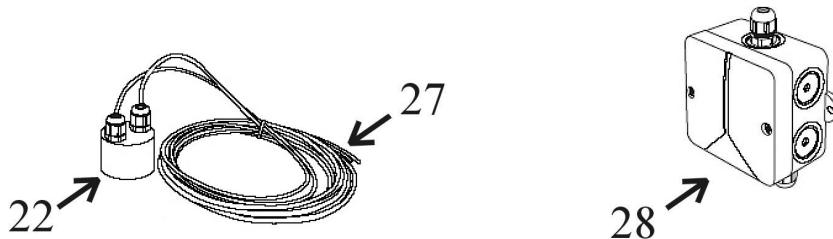

Picture 3: Sensor technology



1. Now the sensor measurement pick-up **[28]** (cover removed) should be installed on the tank wall (preferably in the man hole shaft of the Graf synthetic tank). The location of the mounted sensor pick-up should be between 10 and 15 cm above the overflow **[25]**. The enclosed screws should be used to secure the device. After fully tightening the screws, the points that are showing themselves on the outside of the tank must be blunted to avoid injury **[24]**.
2. Measure the height from the bottom of the tank **[23]** to the end of the terminals **[15]** and **[16]** on the measurement pick-up **[28]**.
3. Shorten the connection cable to suit the measured height.
4. Connect the sensor cable to the sensor as described in the following instructions: Remove between 5-7 mm of the insulation from both of the cables. Next, pass the red cable through the screw mounting 1 **[19]** and tighten this lightly, then connect the red cable to the terminal **[16]**. The free white cable is now passed through the screw mounting 2 **[18]** and tightened lightly, then connect the white cable to the terminal **[15]**.
5. Now pass the end of the data cable that has no plug connector **[12]** through the screw mounting 3 **[13]**. Lightly tighten the screw mounting and connect the cable wire cores of the data cable **[12]** to the double terminal **[14]**. The connection of the data cable is reverse polarity protected. **Attention! The screws should be tightened with care to ensure that they are not damaged through over tightening.**
6. Now recheck that all the screwed items and the sensor components have been fitted correctly. **Replace the cover of the measurement pick-up and secure this with the appropriate fastening screws.**

7. The installation of the data cable [12] to the system control must be according to good professional practice to constitute a correct completion of the sensor technology: A protective cable conduit must be used. (The data cable is not suitable for installing directly in the earth). The end of the data cable that is still unconnected is fitted with a plug connector. This is to be plugged into the appropriate socket [3] of the system control.

**Note:**



The red and the white cable going down to the probe should be straight and smooth to be drawn taught by the weight of the stainless steel probe. The stainless steel probe must hang just above the tank floor.

The following illustration clarifies the context:

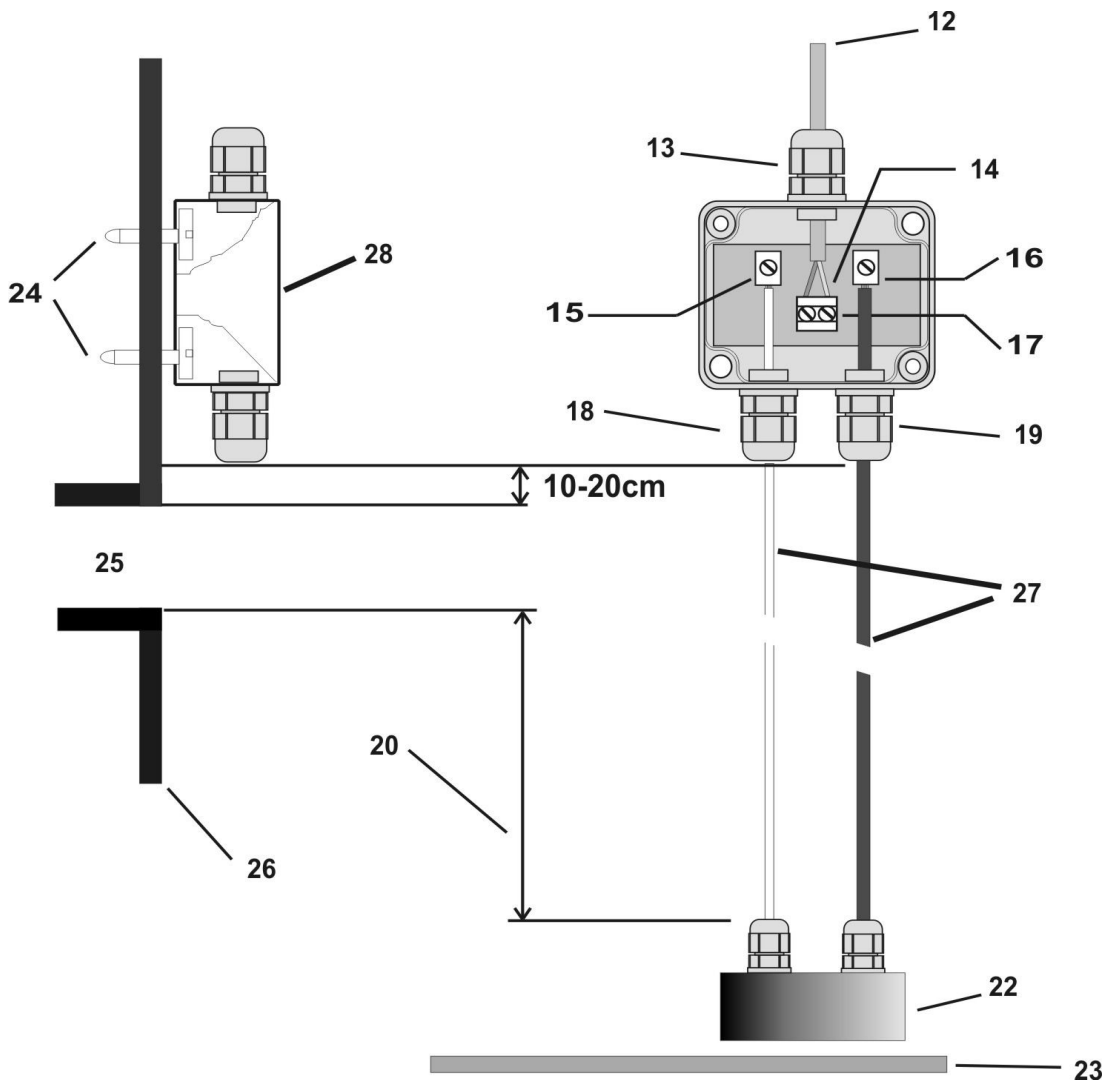

**12:** data cable

**13:** screw cap 3

**14:** Connection of the data cable is reverse protected.

**15:** connect white cable here

**16:** connect red cable here

**17:** data cable terminal

**18:** screw cap 2

**19:** screw cap 1

**20:** active measuring length

**22:** stainless steel probe

**23:** tank floor

**24:** Screws must be blunted! (Danger of injury.)

**25:** overflow

**26:** tank side in dome

**27:** Sensor

**28:** Sensor control box

Picture 4: Connecting sensors equipment

## 5. Putting into operation and calibration process

Before the putting the equipment into operation check and be sure that all electrical connections are correctly insulated and all covers are properly closed!

Now plug the wall power supply into the mains socket particular to the equipment. In the LCD display there is a run through range of number combinations shown. These are used in the initialization of the equipment. The initialization is completed as soon as the value stops and stays still, i.e. the display shows no further fluctuation. The device now runs with the factory standard settings (measuring cable length of 2 m). Should you have a different measuring cable length then the device must be calibrated. To do this proceed as follows:

### ***Calibration procedure:***

1. Fill the tank up to the maximum height.

***If this is not possible then you should proceed with the alternative as follows:***

- Fill a bucket with water.
- Put in the stainless steel probe with the red and white cables attached in the required measuring lengths completely submersed in the water then continue as from point 2

2. Press the calibration button. The code **"901"** is shown in the LCD display.
3. Release the calibration button and wait until the code **"902"** is shown in the LCD display.
4. Now press the calibration button again, short, to save the determined value. The code **"903"** is shown briefly in the LCD display.
5. After this wait for a few moments until the display shows 100%.



After the code "902" appears the calibration button must be ***immediately*** pressed, if this is not done then the value will not be saved. If this happens then wait a moment and repeat the process.

After the completion of the calibration, the fill level indicator is shown in %, in this case 100% shows. (Slight variations may be caused by disturbance of the waters surface).



It is possible to re-set the fill level indicator to the factory settings at any time. To do this, pull the plug from the mains and wait for a few seconds. After this press the calibration button and hold it pressed and re-plug the device into the mains. Hold the button pressed until the LCD code "601" is shown in the display.

## 6. Error messages and fault elimination

Directly following switching on and during the operation mode the digital fill level indicator checks the complete system equipment. If an error is diagnosed it will be shown on the LCD display.

**602** - The calibration process has not been carried out correctly.

This error code 602 occurs when the calibration button has been held too long. In this case repeat the calibration process.

**701** - Sensor error (the pick up sensor sends no signal)

Start with a check of all the connections of the data cable in the display device and on the pick up sensor. Control also for faulty cables (check for current). Check also the terminals of the sensor pick up electrodes.

A further reason for this signal could be the sensor cable ([27] in figure 3). In particular the white sensor cable may have absolutely no electrical contact to the water in the tank.

Inspect this cable for any damage. It may be necessary to use a magnifying glass to ensure there is no damage or split.

Whether the defect is on the measurement sensor pick-up or the sensor cable is simple to define. Take the sensor cable together with the stainless steel weight completely out of the tank. The measurement sensor pick-up remains connected.

The unit display must now show a value of 0% (there may still be rest moisture). If the unit now shows a value 0%, then the sensor cable is damaged.

If the unit continues to display the error code "701", then the measurement sensor pick-up is defect.

If all the cables have been correctly attached and there are no short circuits then the digital fill level indicator must function properly. When the "701" code is still in the display then remove the sensor completely from the tank (the sensor pick up remains attached). The device must now show a value of 0 %. If this is not the case then the sensor is not functioning properly.

## 7. Disposal of the equipment

Old equipment may not be disposed of in the house refuse. It must be brought to the recognised professional recycling depot.

*Please help – ensure your old electronics come to a separate recycling.*

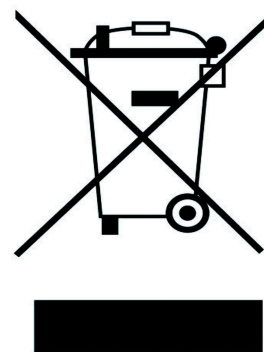

## 8. Manufacturer

Should you have any problems with the equipment, please contact:

**VEINLAND** GmbH

Niederlassung Prenzlau

Franz Wienholz Str. 40

D- 17291 Prenzlau

Tel. : +49 3984- 80 87 17

Fax : +49 3984- 80 69 61

Internet : [www.veinland.net](http://www.veinland.net)

Mail : [info@AS-Prenzlau.de](mailto:info@AS-Prenzlau.de)

**We prefer to receive an E-Mail, if you must contact us then be sure to enter the serial number of your controller that begins with “AS”.**



The serial number is found on the name/type label.

Revision history:

Revision	Date	Description	Author
Graf-FSA 2.0	13.02.2018	Formatting A5	SU
Graf-FSA 2.1	02.12.2019	Formatting A4	SU

Purchase date : .....

Device serial number / Type : AS DF .....

**Design and specifications are subject to change without notice.**

Dated: December 2019

man\_Graf-FSA\_2-1\_eng.odt